

Unterwagen stationär 6,0 m
undercarriage stationary 6,0 m /
châssis porteur fixe 6,0 m

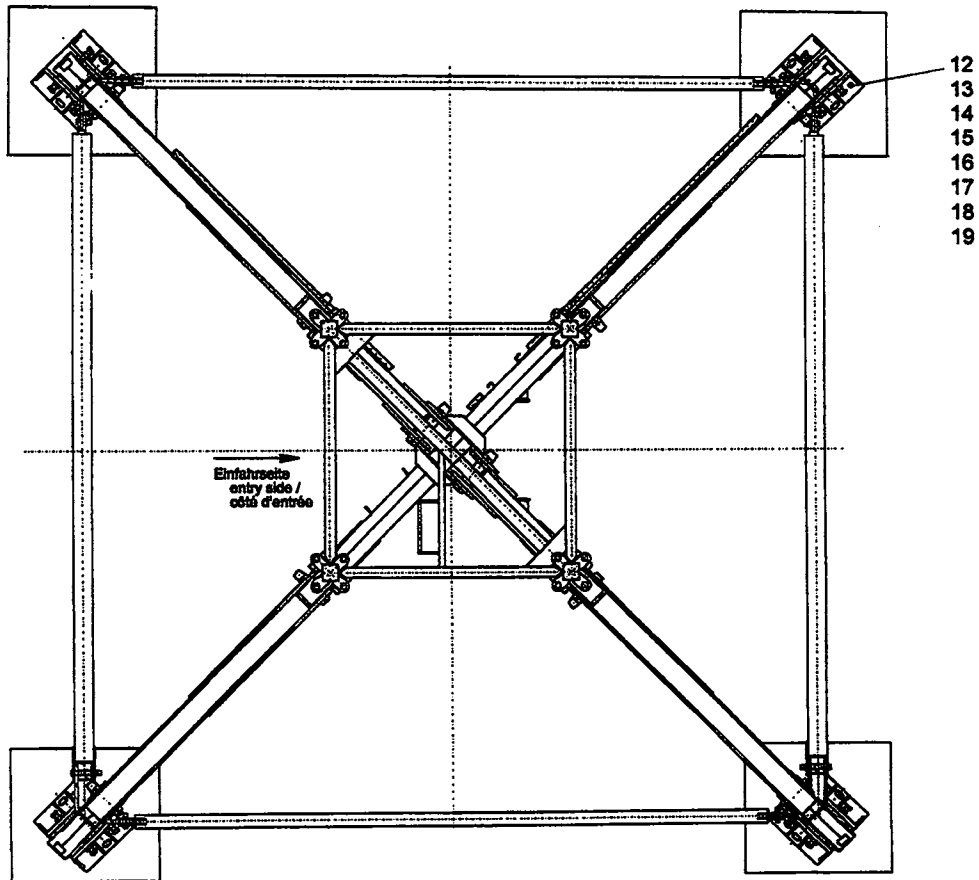

Montage

256 HC / 290 HC Unterwagen stationär 6m Spurbreite

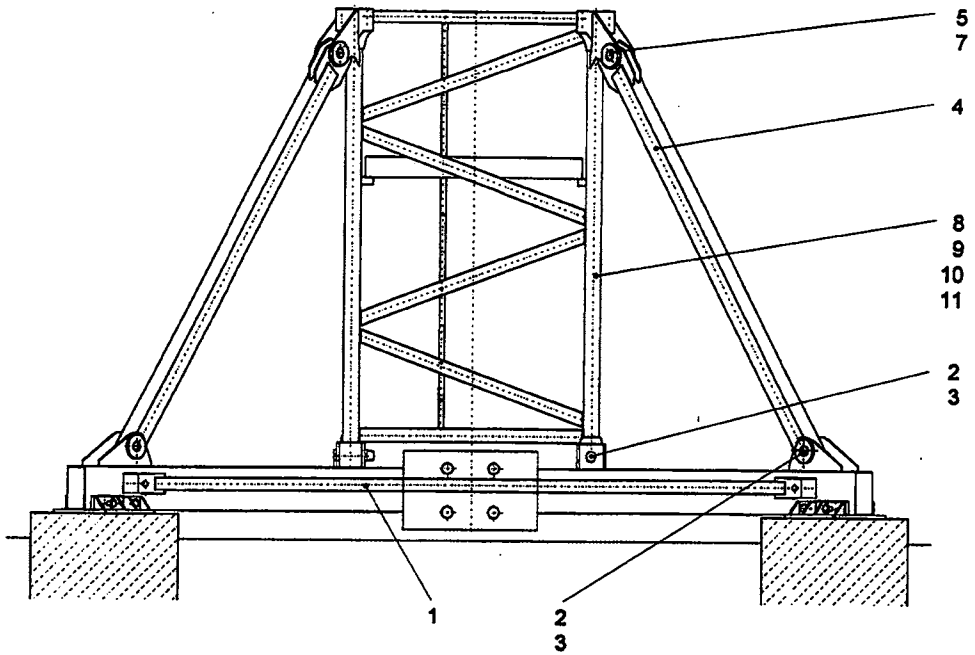

Gewicht:
 Unterwagen komplett ca. 8,7 t
 Unterwagen ohne Ankerschuhe ca. 8,2 t

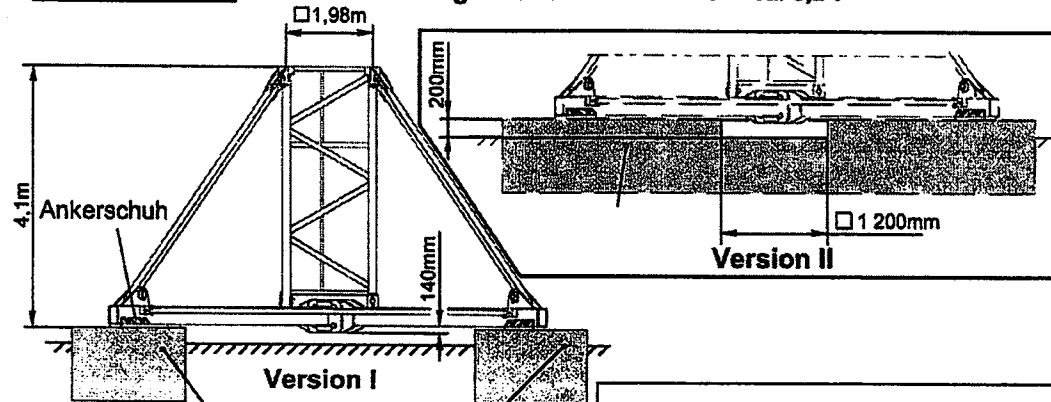

Fundamentplatten entsprechend den Eckkräften und Bodenverhältnissen ausführen!

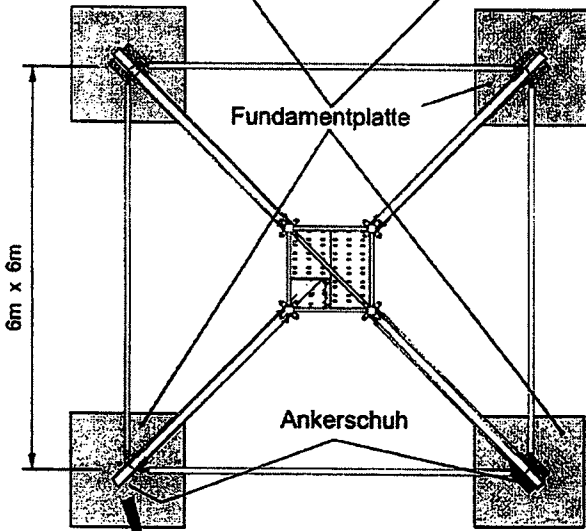

← Kletterseite

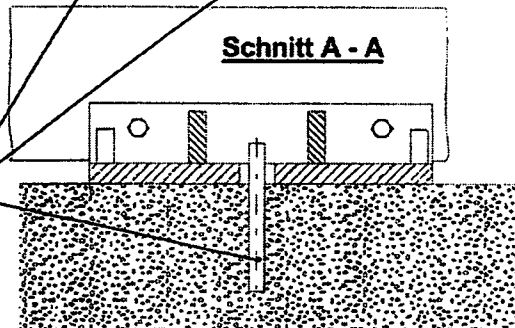
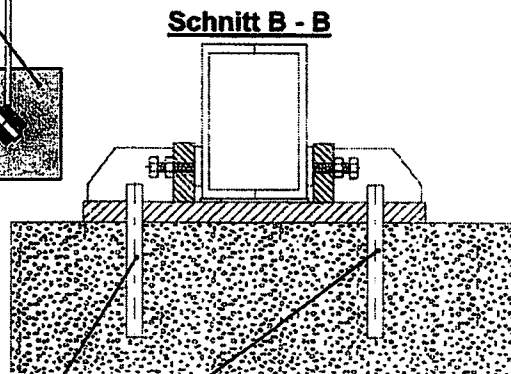
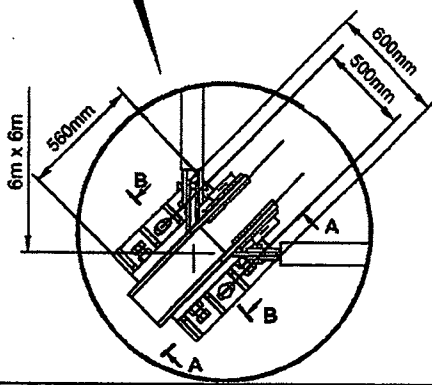

Unterwagen, nach dem Aufsetzen auf die Fundamentplatten, gegen Verrutschen sichern!

256hc_uw-6m.dst

Zentralballast, siehe Eckkrafttabellen Kapitel 2!