

KRUPINSKI CRANES

KR 15 RAPID

KR Drives[®]



37 kWh / 100

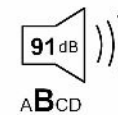

Schnelleinsatzkrane

Fast-erecting crane/Żuraw szybko montujący

KR 15 RAPID



Technische daten:

Technical data:

Dane techniczne:

Max. Traglast 1.5 t

Max. capacity
Maks. udźwig

Max. Ausladung 20 m

Max. jib-length
Maks. wysięg



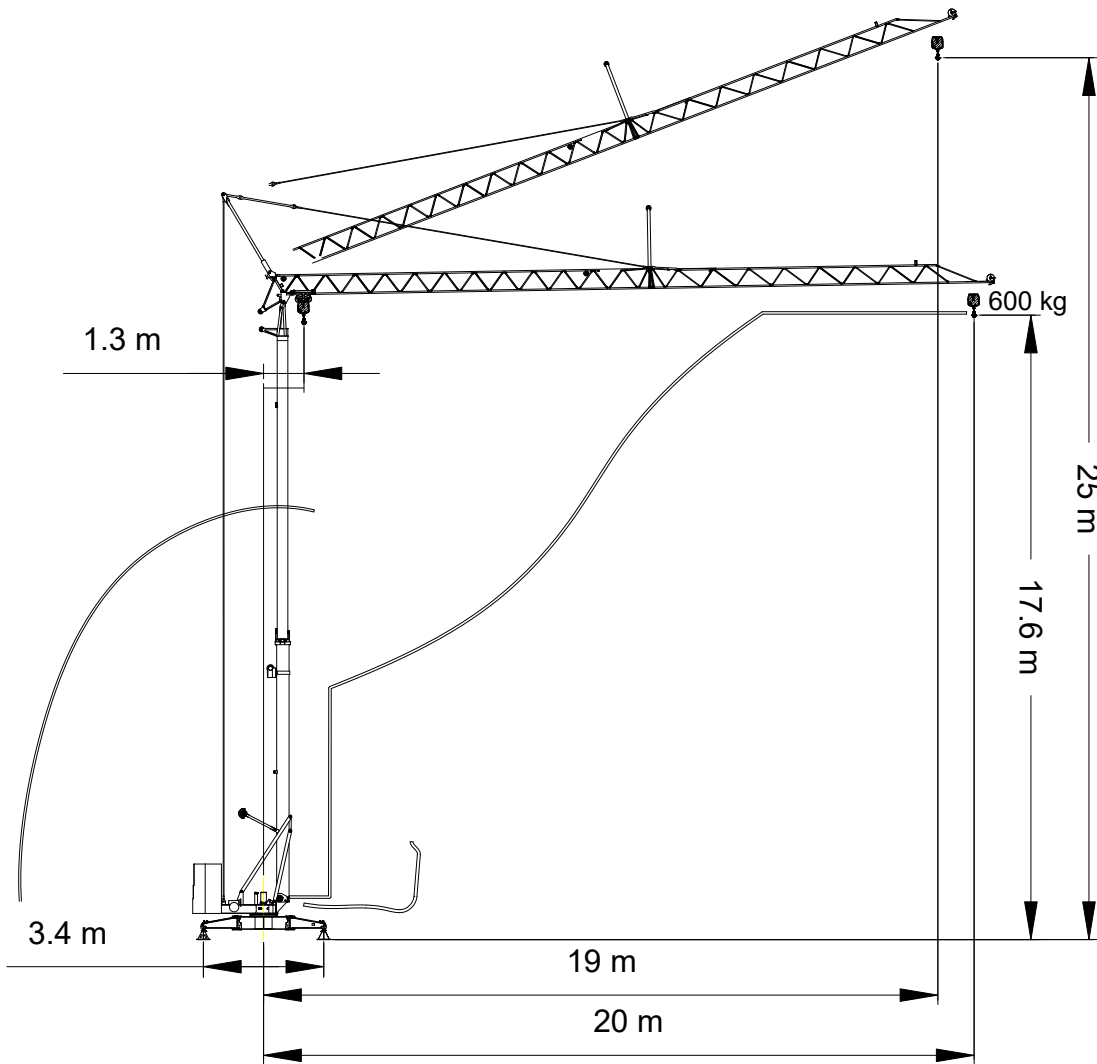

Aufstellvorgang und Transport





Erection and transport/Montaż i transport



Traglastabelle

Table of capacity/Tabela udźwignów



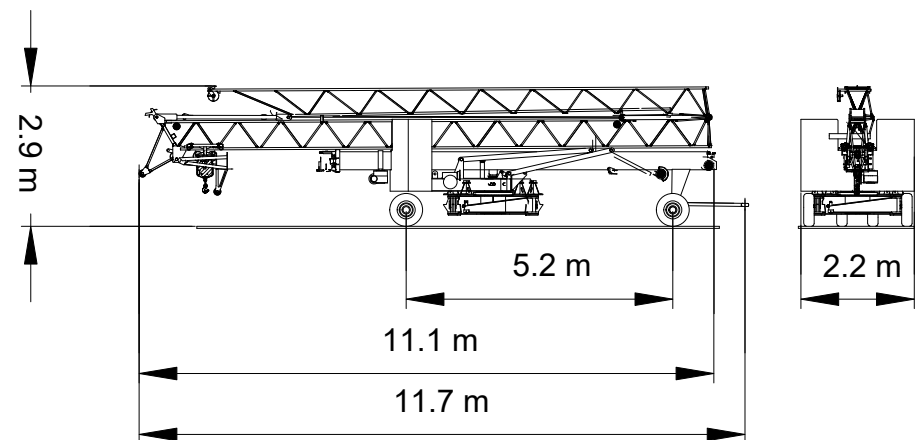
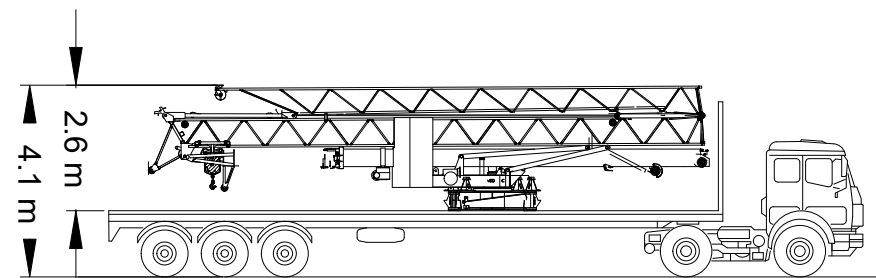

| | | | | | | |
|---|---|---|---|-----|-----|-----|
|  |  |  |  | | | |
| [m] | 1500 [kg] | 9 | 12.5 | 16 | 17 | 20 |
| 20.0 | 1.3 - 9.0 | 1500 | 1020 | 756 | 702 | 600 |

| | | | | | | |
|---|---|---|---|-----|-----|-----|
|  |  |  |  | | | |
| [m] | 600 [kg] | 9 | 12.5 | 16 | 17 | 19 |
| 19.0 | 1.3 - 19.0 | 600 | 600 | 600 | 600 | 600 |



Antriebe

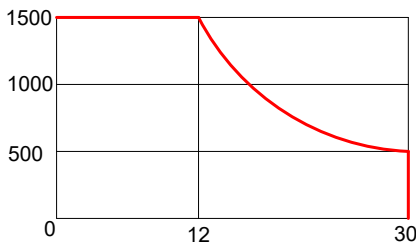









Data of drives/Dane napędów

| | | | |
|---|--|--|---|
|  | $V \rightarrow 0 - 30 \frac{m}{min}$ | 1.5 kW | 400 V 50 Hz |
|  | $V \rightarrow 0 - 1.0 \frac{1}{min}$ | 1.5 kW | 3 Ph |
|  | | Max. HH für: HH max. for winch type: HH maks. dla wciągarki typu: Standard = 25 m | |
| Art Type/Typ FU/H 4.4 4.4 kW |  <p>Hubgeschwindigkeit $\frac{m}{min}$ Hook velocity/Prędkość haka $\frac{m}{min}$</p> |  1.5 t | Versorgungsspannung AC Supply voltage Napięcie zasilania 400 V / 230 V |
| | | | Antriebsleistung gesamt Max motor output Suma mocy silników ~7.4 kW |
| | | | Anschlussleistung Connected power Moc przyłączeniowa 8.9 kVA |

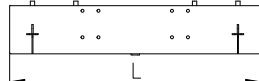
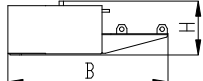
Nach Norm EN 14439
All data refer to standard EN 14439
Zgodnie z normą PN-EN 14439

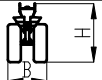
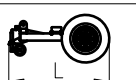
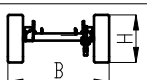
Kolli-Liste

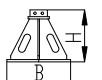
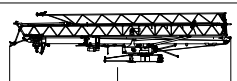
Packing list/Lista elementów

| Pos. Item Lp. | Anz. Qty. Ilość | Teil Element |  |  | | L [m] | B [m] | H [m] | Gewicht* Weight* Waga* [kg] |
|---------------|-----------------|---|--|---|---|-------|-------|-------|-----------------------------------|
| 1 | 4 | Ballast Ballast Balast |  |  | links / left / lewy rechts / right / prawy | 0.78 | 0.87 | 0.90 | 4x1100 |
| 2 | 1 | Ballastbasis Ballast base Podstawa balastu |  |  | | 2.20 | 1.40 | 0.47 | 1807 |
| 3 | 1 | Transportachse vorne Road transport axle front Oś przednia |  |  | | 7.88 | 2.58 | 3.87 | 216 |
| 4 | 1 | Transportachse hinten Road transport axle behind Oś tylna |  |  | | 6.66 | 6.71 | 3.15 | 485 |
| 5 | 4 | Stützpirmide Pyramidal support Podpora |  |  | | 0.38 | 0.33 | 0.27 | 4x15 |
| 6 | 1 | KR 15 RAPID gefalteter KR 15 RAPID folded KR 15 RAPID złożony |  |  | | 11.44 | 1.83 | 2.57 | 4300 |

*Montagegewichte siehe Betriebsanleitung
*Mounting weights see: Manual instruction
*Ciężary montażowe patrz: Instrukcja Obsługi

www.krupinskicranes.com



Änderungen vorbehalten! Sämtliche Angaben erfolgen ohne Gewähr
Subject to alterations! This information is supplied without liability.
Producent zastrzega sobie prawo do wprowadzania zmian.

PN-EN 14439 | C.0.10.0012 (BGL) | A3 (FEM 1.001) | HD4 HC1 (PN-EN 13001-2)